

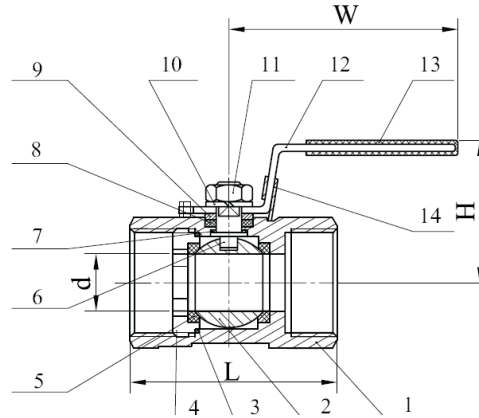

BDE (NORTHAMPTON) LTD

PN69 STAINLESS STEEL 1 PIECE BALL VALVE



FEATURES

- Screwed BSP Taper
- RPTFE (15%) Seats
- PTFE Seals
- Reduced Bore
- PN69 Rated
- Locking Device

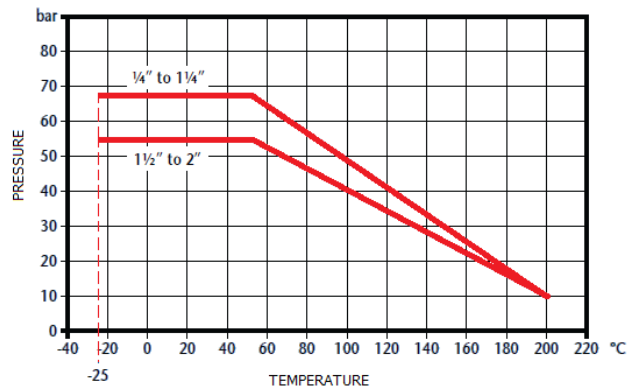

DN	1/4"	3/8"	1/2"	3/4"	1"	1.25"	1.5"	2"
D	5	6.8	9.5	12.7	16	20	25	32
L	40	45	56	59	71	76	85	99
H	32	33	43	45	48	58.3	67	74
W	67	67	93	93	93	106	128	128
Torque	4	4	6	6	8	10	14	15
Kgs	00.9	0.12	0.19	0.28	0.39	0.58	0.85	1.35

ITEM	PART NAME	MATERIAL
1	Body	CF8M
2	Ball	316 Stainless Steel
3	Ball Gasket	PTFE
4	Cap	CF8M
5	Ball Seat	R-PTFE (15%)
6	Stem	316 Stainless Steel
7	Thrust Washer	PTFE
8	Stem Packing	PTFE
9	Washer	304 Stainless Steel
10	Spring Washer	304 Stainless Steel
11	Nut	304 Stainless Steel
12	Handle	304 Stainless Steel
13	Handle Cover	Plastic
14	Lock Device	304 Stainless Steel

TECHNICAL DATA

- Maximum Pressure: 1/4" - 1.25" = 69 Bar
1.5" - 2" = 55 Bar
- Working Temperature: -25°C to +200°C